

Assembly instruction DSPK-SL Series

Use two halves of strain relief and attach the strain relief around the outer jacket. Different sizes of the strain relief can be mixed together to give the best fit. For cable diameters exceeding 9 mm, assembly without the strain relief or with just one strain relief half is applicable.

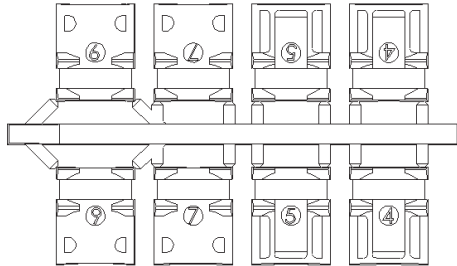

Attach the strain relief around the outer jacket.

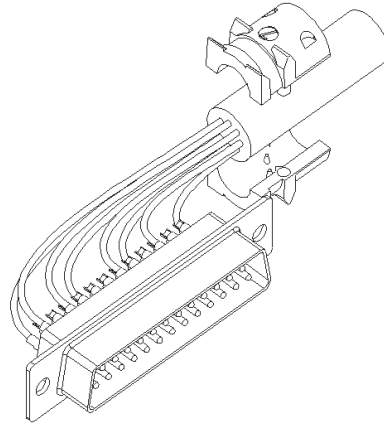

Mount connector and cable into the back shell.

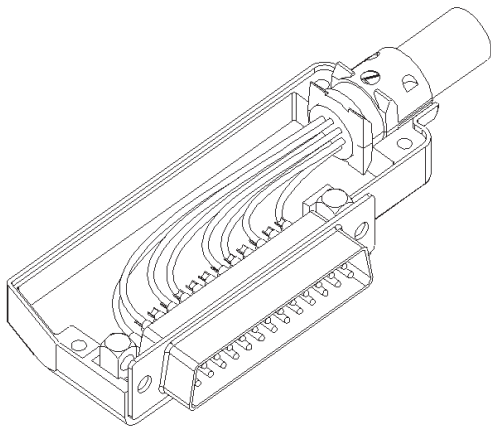

Assemble bottom half and top half with the three assembly screws. Maximum mounting torque is 100 - 120 Ncm.

