

# Assembly instruction DTZK-CZA Series

Prepare cable as illustrated below. Slide crimp ferrule over the outer cable jacket.

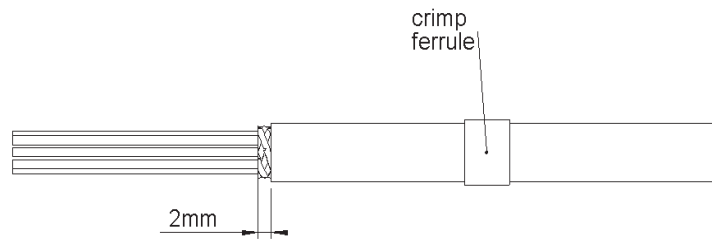

Put wires through and shape cable metal braid around the anchor ferrule.

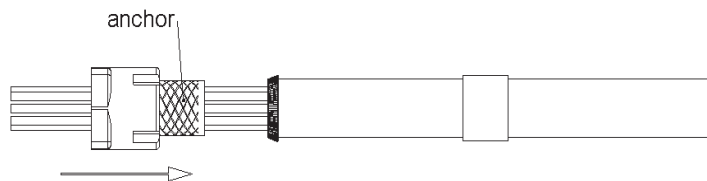

Slide the crimp ferrule into position over outer cable jacket aligned with the anchor ferrule.



Crimp over the crimp ferrule and mount the D-Sub connector.

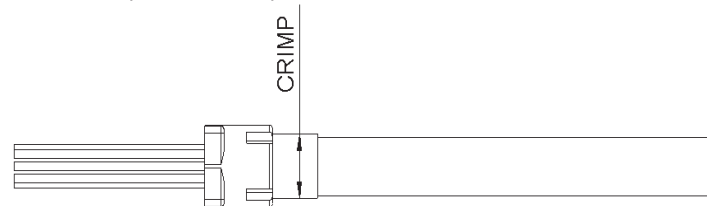

Place the assembled connector and crimped cable into the bottom back shell half.

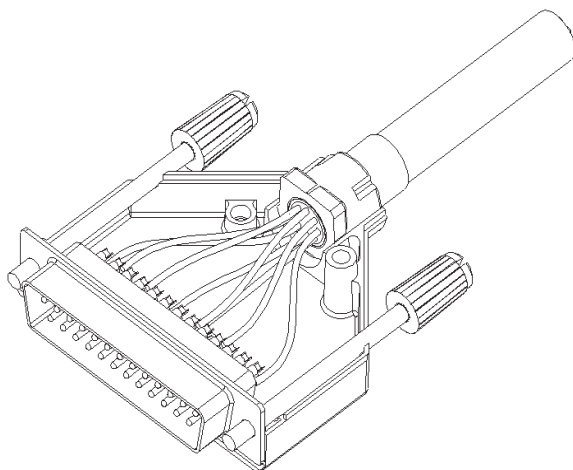

Complete the assembly by putting the top half over the assembly and tighten with accompanied assembly screws. Maximum mounting torque is 100 - 120 Ncm.

