

Assembly instruction DVPK Series

Use two halves of strain relief and attach the strain relief around the outer jacket. Different sizes of the strain relief can be mixed together to give the best fit. For cable diameters exceeding 9 mm, assembly without the strain relief or with just one strain relief half is applicable.

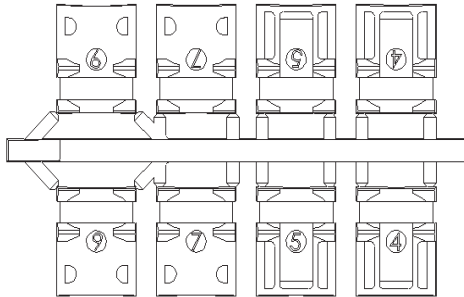

Attach the strain relief around the outer jacket.

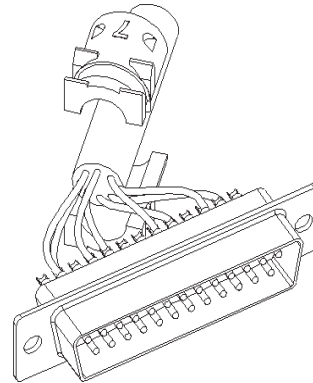

Place the assembled connector and cable into the bottom back shell half.

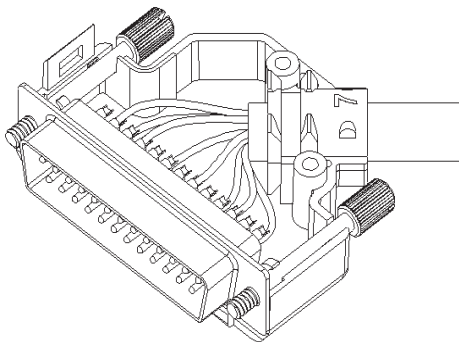

Complete the assembly by putting the top half over the assembly and tighten with accompanied screws. Maximum mounting torque is 100 - 120 Ncm.

